

QUARZI

HC-49US SMD

Codice Adimpex: **LQT20000-R**

QUARZO HC-49U/S SMD20.000 MHZ 30pf
p/n:SM1970FATR

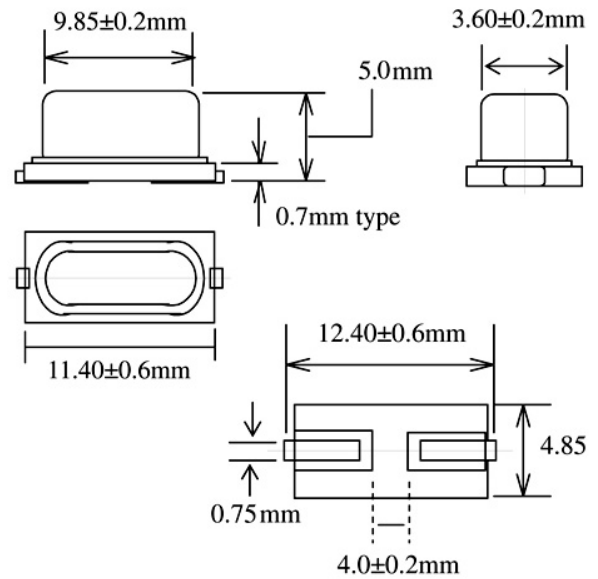
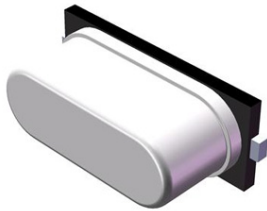

Codice Adimpex	Frequenza (MHz)	Vibrazione	Capacità di carico
LQT03579	3.579545	Fundamental	30
LQT04000	4.000000	Fundamental	30
LQT04915	4.915200	Fundamental	20
LQT06000	6.000000	Fundamental	30
LQT08000	8.000000	Fundamental	30
LQT10000	10.000000	Fundamental	30
LQT11059	11.059200	Fundamental	20
LQT12000	12.000000	Fundamental	30

Codice Adimpex	Frequenza (MHz)	Modo di vibrazione	Capacità di carico
LQT12288	12.288000	Fundamental	30
LQT14745	14.745600	Fundamental	20
LQT16000	16.000000	Fundamental	30
LQT18432	18.432000	Fundamental	16
LQT20000	20.000000	Fundamental	30
LQT24000	24.000000	Fundamental	30
LQT24576	24.576000	Fundamental	30

CARATTERISTICHE

Contenitore	HC-49U	HC-49US HC-49US SMD
Gamma di frequenza	1.843200 ÷ 100 MHz	3.2 ÷ 100 MHz
Tolleranza in frequenza	± 30 ppm (25°C)	± 50 ppm (25°C)
Livello di pilotaggio	10 µW ÷ 0.5 mW	
Stabilità in temperatura	± 50 ppm	
Gamma di temperatura	-10°C ÷ 60°C	
Capacità shunt	7 pF max.	
Resistenza di isolamento	500 MΩ min.	
Invecchiamento	± 5ppm / year	

FEATURES

Holder type	HC-49U	HC-49US HC-49US SMD
Frequency range	1.843200 ÷ 100 MHz	3.2 ÷ 100 MHz
Frequency tolerance	± 30 ppm (25°C)	± 50 ppm (25°C)
Drive level	10 µW ÷ 0.5 mW	
Temperature stability	± 50 ppm	
Operating temperature range	-10°C ÷ 60°C	
Shunt capacitance	7 pF max.	
Insulation resistance	500 MΩ min.	

Aging

± 5ppm / year