

CONDENSATORI AL TANTALIO IN CHIP

Serie CS

Codice Adimpex: **DTD11016-R**

COND. EL. TANT. Msmd 100uF 16V -D

p/n: CSD1C107MTR RoHS

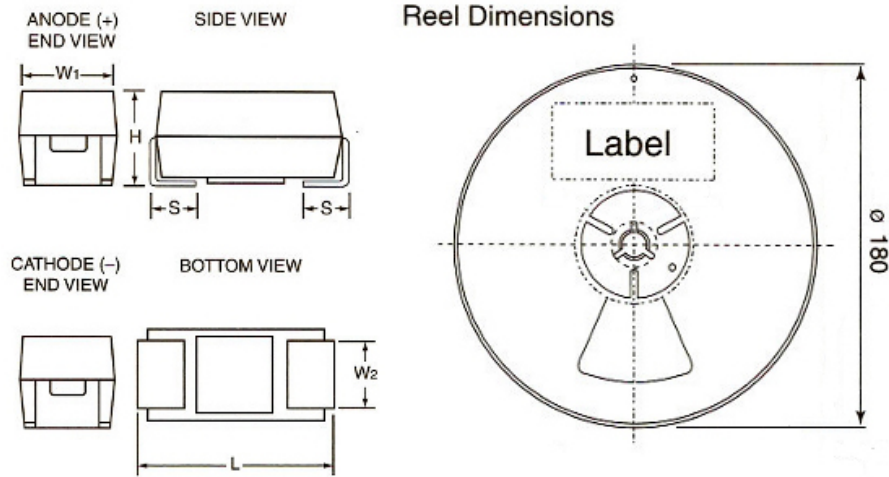
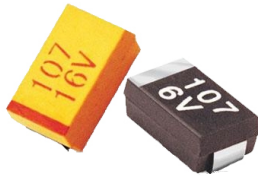

Codice Case

DTA =
codici per il
case A

DTB =
codici per il
case B

DTC =
codici per il
case C

DTD =
codici per il
case D

Tensione (V)	6.3	10	16	20	25	35	50
Capacità (uF)	Codice Adimpex						
0.1						DTA-1035	DTA-1050 DTB-1050
0.15						DTA-1535	DTA-1550 DTB-1550
0.22						DTA-2235	DTA-2250 DTB-2250
0.33					DTA-3325	DTA-3335	DTB-3350
0.47				DTA-4720	DTA-4725	DTA-4735	DTB-4750 DTB-4735 DTC-4750
0.68			DTA-6816	DTA-6820	DTA-6825	DTA-6835	DTB-6850 DTB-6835 DTC-6850
1.0		DTA.1010	DTA.1016 DTB.1016	DTA.1020 DTB.1020	DTA.1025 DTB.1025	DTA.1035 DTB.1035 DTC.1035	DTB.1050 DTC.1050
1.5	DTA.1506	DTA.1510	DTA.1516 DTB.1516	DTA.1520 DTB.1520	DTA.1525 DTB.1525	DTA.1535 DTB.1535 DTC.1535	DTA.1550 DTB.1550 DTC.1550
2.2	DTA.2206	DTA.2210	DTA.2216 DTB.2216	DTA.2220 DTB.2220	DTA.2225 DTB.2225	DTB.2235 DTC.2235	DTD.2250
3.3	DTA.3306	DTA.3310	DTA.3316 DTB.3316	DTA.3320 DTB.3320	DTA.3325 DTB.3325 DTC.3325	DTB.3335 DTC.3335 DTD.3335	DTD.3350
4.7	DTA.4706	DTA.4710	DTA.4716 DTB.4716	DTA.4720 DTB.4720 DTC.4720	DTA.4725 DTB.4725 DTC.4725	DTC.4735 DTD.4735	
6.8	DTA.6806	DTA.6810 DTB.6810	DTA.6816 DTB.6816	DTB.6820 DTC.6820	DTB.6825 DTC.6825	DTC.6835 DTD.6835	
10	DTA01006 DTB01006	DTA01010 DTB01010	DTA01016 DTB01016 DTC01016	DTB01020 DTC01020	DTB01025 DTC01025 DTD01025	DTC01035 DTD01035	
15	DTA01506 DTB01506	DTA01510 DTB01510 DTC01510	DTB01516	DTC01520 DTD01520	DTC01525 DTD01525	DTD01535	
22	DTA02206 DTB02206 DTC02206	DTA02210 DTB02210 DTC02210 DTD02210	DTB02216	DTC02220 DTD02220	DTC02225 DTD02225		
33	DTA03306 DTB03306 DTC03306	DTB03310 DTC03310 DTD03310	DTC03316 DTD03316	DTC03320 DTD03320	DTD03325		
47	DTA04706 DTB04706 DTC04706 DTD04706	DTB04710 DTC04710 DTD04710	DTC04716 DTD04716	DTD04720	DTD04725		
68	DTB06806 DTC06806 DTD06806	DTB06810 DTC06810 DTD06810	DTD06816	DTD06820			

100	DTB11006 DTC11006 DTD11006	DTC11010 DTD11010	DTD11016
150	DTC11506 DTD11506	DTD11510	
220	DTC12206 DTD12206	DTD12210	
330	DTD13306		
470	DTD14706		

CARATTERISTICHE

- Tolleranza: $\pm 20\%$
- Gamma di temperatura: $-55^{\circ}\text{C} \div +125^{\circ}\text{C}$
- Tensioni di lavoro: $4\text{V} \div 50\text{V}$
- Corrente di fuga: $\leq 0.01\text{ CV} [\mu\text{A}]$
o $0.5\mu\text{A}$ il maggiore dei due
- Prove di vita: 1000 ore a 125°C

FEATURES

- *Capacitance tolerance: $\pm 20\%$*
- *Operating temperature range: $-55^{\circ}\text{C} \div +125^{\circ}\text{C}$*
- *Operating voltage: $4\text{V} \div 50\text{V}$*
- *Leakege current: $\leq 0.01\text{ CV} [\mu\text{A}]$ o $0.5\mu\text{A}$ whichever is greater*
- *Load life: 1000 hours at 125°C*

Dimensioni (mm)

Case	L ± 0.2	W1 ± 0.2	H ± 0.2	S ± 0.2	W2 ± 0.2
A	3.2	1.6	1.6	0.8	1.2
B	3.5	2.8	1.9	0.8	2.2
C	6.0	3.2	2.5	1.3	2.2
D	7.3	4.3	2.8	1.3	2.4