

### INTERRUTTORI A SLITTA

**PCB orizzontale passo 4.0mm**

Codice Adimpex: **BL501560-R**

INTER SLID.SV70050F-0202-6T NN

Serie:SV70050F

p/n:SV70050F-0202-6T-NN

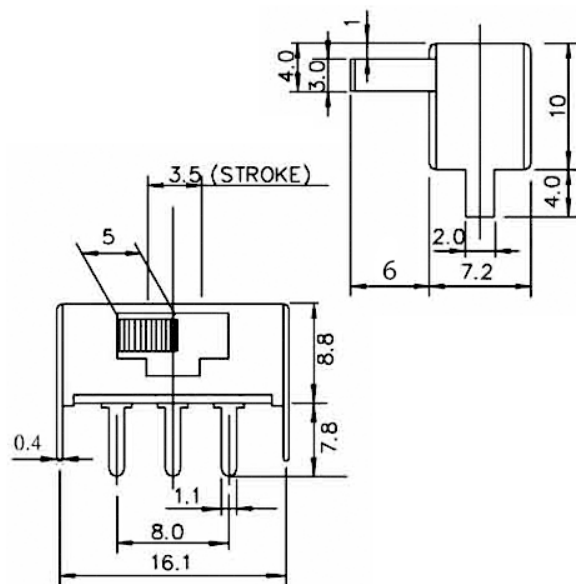
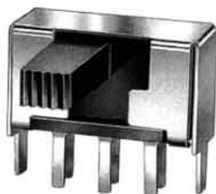

Codice Adimpex	circuito	travel	forza di attuazione	timing
BL501560	2P - 2T	3.5	500 ± 200 gr.	non-shorting

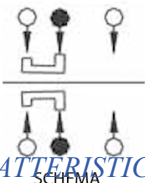

### CARATTERISTICHE

- Portata: 0.3 A, 50V DC
- Rigidità dielettrica: min. 500V AC per 1 minuto
- Resistenza di contatto: 30 mΩ max.
- Durata (cicli): 10.000 senza carico
- Resistenza di isolamento: 100 MΩ min.
- Temperatura di lavoro: -10°C ÷ 60°C

### FEATURES

- Rating: 0.3 A, 50V DC
- Dielectric strenght: min. 500V AC for 1 minute
- Contact resistance: 30 mΩ max.
- Life (cycles): 10.000 without load
- Insulation resistance: 100 MΩ min.
- Operating temperature: -10°C ÷ 60°C